

Stream ALPHA Plus Stream ALPHA Component Stream ALPHA SDI Stream WIND SDI

Graphics overlay cards

User Manual

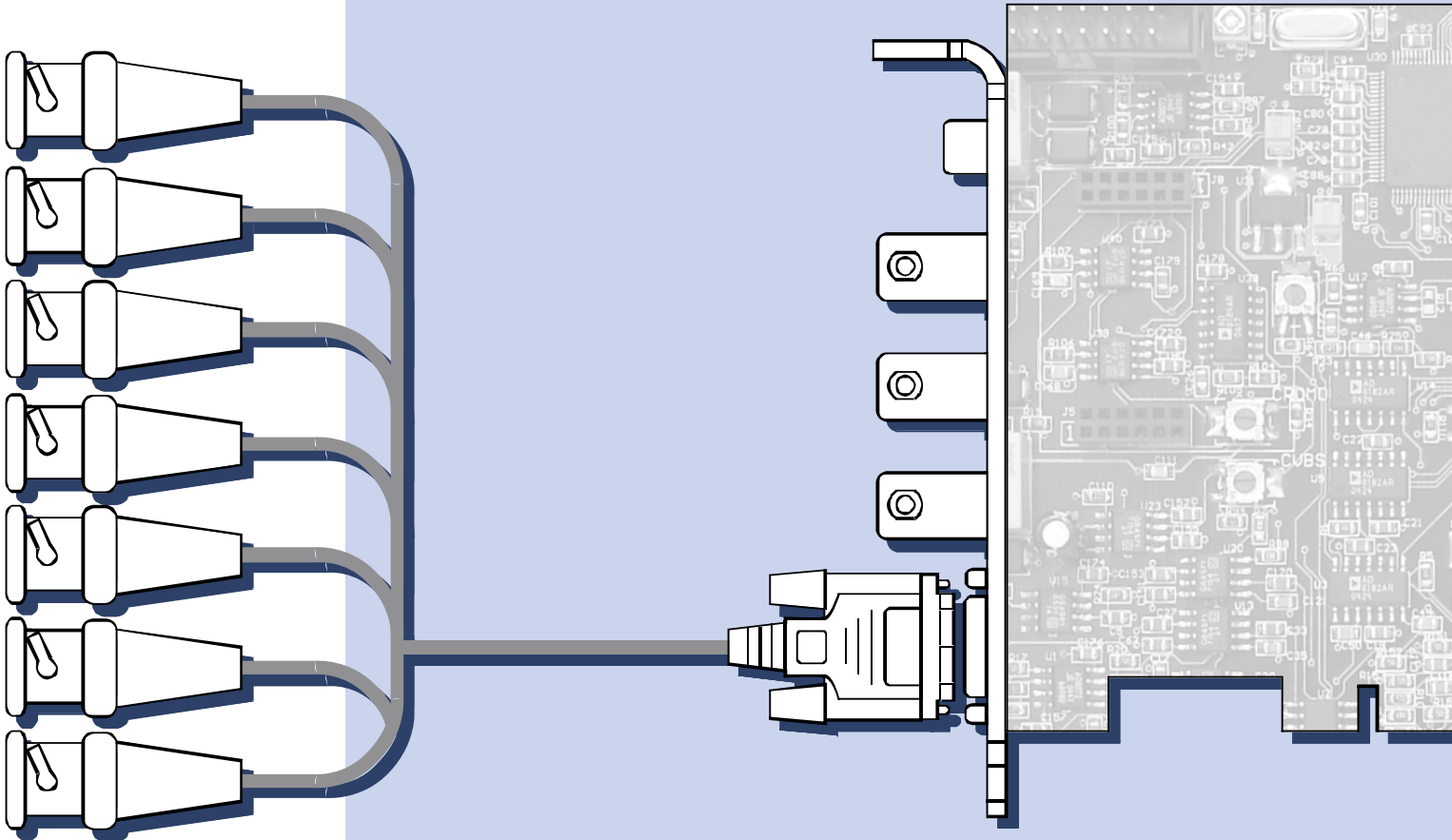

Support

Stream Labs technical support team is always ready to answer your questions. If you should experience any problems, errors or issues in our hardware or software operation, please contact us by e-mail: support@stream-labs.com. Please describe the problem as thoroughly as possible and attach screenshots.

Concerning emergencies and urgent help you also can contact us by Skype: streamlabs911 or streamlabs-support.

We will be happy to assist you in the fastest and most effective way!

Warranty

Stream Labs offers 3-year warranty on Stream ALPHA and Wind SDI series cards. This includes a free-of-charge repair in case of defects that have arisen due to our fault or the fault of the manufacturers of components. The manufacturer is not liable for faults caused by misuse of the product.



WARNING! Do not switch the connection cables while the computer or video equipment is operating. This will damage the video system, computer and video equipment. Prior to any switching operation, all equipment must be de-energized by disconnecting the power cables (the connection of cases of the devices to earth and to each other should be left intact)! When the switching is performed incorrectly, input and/or output stages on cards (devices) fail. **The warranty does not extend to such malfunction!**

Copyright

Hardware and software components included in Stream Alpha card package may not be copied or transferred in any form without prior coordination with Stream Labs.

Contact information

Russia, 127273 Moscow, Berezovaya Alleya 5A, bldg 5

Tel.: (495) 739-82-42 (multichannel)

E-mail: info@stream-labs.com

Skype: streamlabs911 or streamlabs-support

Web: <http://www.stream-labs.com>

Contents

Professional TV character generation and broadcast automation is our specialty	5
System components – Hardware	6
Stream ALPHA Plus PCI-E graphics overlay card	6
Stream ALPHA SDI graphics overlay card	8
Stream WIND SDI graphics output card	9
Stream WIND SDI II graphics overlay card	10
WatchDog USB timer	11
System components – Software	13
Alpha Pro 2.0 character generation software	13
TELE 2.2 on-air automation and information/graphic broadcast design software	15
DvDelay software module	17
Detect software module	17
Thermo software module	17
TELE Info software module	18
TELE IP	20
TELE Info IP	20
SMS Terminal software module	20
Package contents	21
Assignment of card connectors	23
Stream ALPHA Plus PCI-E	23
Audio BYPASS expansion module for Stream ALPHA Plus PCI-E card	25
Stream Audio extension sound card	25
Stream ALPHA SDI	26
Stream WIND SDI	27
Stream WIND SDI II	27
Connection diagrams	29
Installation and connection	31
Adjusting the settings for Stream Alpha series video cards in Alpha Pro / TELE applications	33
Stream ALPHA Plus PCI-E	33
Stream ALPHA SDI	36

Stream WIND SDI	37
Stream WIND SDI II	38

Professional TV character generation and broadcast automation is our specialty

Stream ALPHA and WIND SDI series graphics overlay cards work in real time and provide titling, output of commercial blocks and design of live TV programs, such as newscasts, weather forecasts, live sports reports, talk shows etc. The system is designed as an open platform, which allows utilizing various software. The station consists of an IBM compatible personal computer equipped with PCI graphics overlay / titling cards and specialized software running on Windows XP/7.

Using this approach we provide the system with flexibility, growth potential and extended functionality through software updates and computer upgrades. Open architecture allows creating a complete station with the intended application in mind. The standard package contains all the necessary interfaces and tools required to use the station as a character generator for program editing and live broadcasting. The extended package, which includes TELE automation system, turns the station into a video server designed to play scheduled bumpers, titles, animation and video clips. This type of station is recommended for television companies that insert regional advertising and programs into their broadcast network lineup.

In regards to the design possibilities, the only limit is the artist's imagination. Various fonts, three-dimensional shadows, semi-transparent masks, textures, complex multi-layered compositions, animations and much more is at your disposal. Moreover, in contrast to character generators included into the non-linear editing equipment, the Stream ALPHA and WIND SDI based systems do not require the digital video disk processing with deteriorated quality due to the compression, disk space consumption and significant time costs required for caption processing.

Our software developers have taken into account the current needs of a considerable number of TV studios across Russia and abroad. Presently, we are able to meet virtually any challenges, from crawl output to interactive program creation, live polls, automated output of blocks of news, commercials, etc.

System components – Hardware

Stream ALPHA Plus PCI-E graphics overlay card

Stream Alpha Plus PCI-E can be used to create on-air graphic design systems (CG systems) and broadcast video servers.

Stream Alpha Plus PCI-E is designed to work with Composite or S-Video signal of PAL, SECAM, NTSC standards. Automatic activation of video signal relay bypass mode upon computer power loss.



YUV component and key (alpha-channel) signal outputs allow to use the card with a mixer that has component and DSK (Down Stream Key) inputs.

In analog mixing mode the pass-through signal is not being decoded, it is passed through the card without changes, while saving all its frequency characteristics and service information.

In digital mixing mode, the signal is decoded by the latest PHILIPS decoder with adaptive comb filter for separating brightness and saturation signals.

While in digital mixing mode, you can use any combination of connections. This reduces the requirements for input signal quality, while preserving the high quality of the output signal.

All output signals pass through active filtration and black level reference. Component output Green signal and key signal (alpha-channel) have built-in video synchronization with disabling option.

In digital mixing and SECAM output mode, color burst sync signals are being introduced to the output stream in accordance with GOST 7845-92 and OST 58-18-96, which allows to use the card to transcode PAL/SECAM, SECAM/PAL video standards.

The options for capturing and hardware scaling of video signal from card input allow resizing the pass-through video stream image in real time in combination with computer graphics overlay, and also working in ChromaKey mode.

Specifications:

Size	188x126 mm
Bus	PCI-Express 1x
Inputs	Composite: PAL/SECAM/NTSC; S-video: PAL, SECAM, NTSC
Outputs	Composite: PAL/SECAM/NTSC; S-video: PAL, SECAM, NTSC; Component YUV; Digital linear key DSK signal alpha-channel output (BNC)
Relay Bypass in case of power failure	CVBS, S-Video
Analog mixing bandwidth	> 10 MHz
Differential nonlinearity	< 0,2%
Alpha channel	256 degrees of transparency
Alpha channel delay adjustment	From -127 to +127 ¼ pixel each
Chrominance subcarrier phase adjustment	From 0 to 360° (256 values)
Adjustment of graphics position relative to sync signal	Within the limits of entire active line with an accuracy to one pixel

Additional YUV cable

A special cable with BNC connectors for the output of YUV / RGB component + Alpha Key signals (used when the card is connected to the mixer through DSK input) from 15-pin card connector.

Audio BYPASS extension card

This small card is placed inside the computer and connected to Stream Alpha Plus PCI-E with a special cable, which sends the relay control signal. The card provides audio bypass mode synchronous with switching on/off the similar mode for pass-through video signal, ex. at computer power cutoff.



In such Stream ALPHA Plus PCI-E card operation design the sound is transmitted through the standard computer Sound Blaster.

Stream Audio extension sound card

The card sits inside the computer and connects to Stream Alpha Plus PCI-E with a special cable, which transfers digital audio



stream and relay control signal. The card provides a professional quality analogue audio track **synchronized** with video (Genlock). This ensures accurate sound insertion into pass-through audio channel. In addition, the card features analog and digital mixing of pass-through and played back audio streams and provides audio bypass mode at computer power cutoff.

Specifications:

- 24-bit audio codec UDA1380.
- 48kHz sampling frequency.
- Audio in signal/noise ratio: 100 dB.
- Audio in channel decompression: 97 dB.
- Audio out signal/noise ratio: 68 dB.
- Audio out channel decompression: 90 dB.

Stream ALPHA SDI graphics overlay card

Stream Alpha SDI is a multifunctional graphics overlay PCI-card. It can be used to create on-air graphic design systems (CG systems) and broadcast video servers.

Stream Alpha SDI is designed to work with 8 and 10-bit serial component SDI signals, in accordance with CCIR656 and SMPTE259m standards. SDI embedded audio is supported. Automatic activation of video signal relay bypass mode upon computer power loss.

Synchronization from input SDI signal or analog Black burst (Composite) signal.

The card has analog inputs and outputs (YUV / RGB and Composite) and allows you to convert between analog and digital SDI video format. The graphics on the analog output of the card is formed simultaneously with the SDI signal.

Analog and digital key signal (alpha-channel) output is provided for use with external mixer that has a DSK (Down Stream Key) input.

When SDI signal passes through the card all the embedded information is kept unchanged, audio can be either kept or changed depending on the situation.

Error control in incoming SDI signals with check total count according to EDH method. EDH packets on the output are formed anew in accordance with SMPTE165 standard.



Specifications:

Size	188x126 mm
Bus	PCI 32bit 33 MHz
Inputs	Composite: PAL/SECAM/NTSC; Component YUV; SD SDI (SMPTE 259M and ITU-R BT.601) PAL/NTSC
Outputs	Composite: PAL/SECAM/NTSC; Component YUV; SD SDI (SMPTE 259M and ITU-R BT.601) PAL/NTSC; Analog linear key DSK signal alpha-channel output (BNC); Digital linear key DSK signal alpha-channel output (BNC)
Relay Bypass in case of power failure	SD SDI with embedded audio
Alpha channel	256 degrees of transparency
Alpha channel delay adjustment	From -127 to +127 1 pixel each
Adjustment of graphics position relative to sync signal	Within the limits of entire active line with an accuracy to one pixel

Stream WIND SDI graphics output card

Stream Wind SDI HD is a graphics output PCI-card. It can be used as a basis for creation of on-air graphic design systems (CG-systems) and broadcasting video servers.



The card is designed to output computer graphics and audio to a mixer or recording device which has SD-SDI input according to SMPTE259M standard. SDI embedded audio is supported.

The card features a digital key signal (alpha channel) output. Key signal delay relative to output graphics has a software controlled wide adjustment range.

The card operates in external sync mode using the input analog video signal. When external synchronization is absent, internal sync generator is used.

EDH packets on the output are formed anew in accordance with SMPTE165 standard.

Specifications:

Size	131x95 mm
------	-----------

Bus	PCI 32bit 33/66 MHz
Inputs	Analog external synchronization input (genlock) Blackburst (BNC)
Outputs	Composite: PAL/SECAM/NTSC; SD SDI (SMPTE 259M and ITU-R BT.601) with embedded audio PAL/NTSC; Digital linear key DSK signal alpha-channel output (BNC).
Alpha channel	256 degrees of transparency
Alpha channel delay adjustment	From -127 to +127 1 pixel each
Adjustment of graphics position relative to sync signal	Within the limits of entire active line with an accuracy to one pixel

Stream WIND SDI II graphics overlay card

Stream WIND SDI II is a PCI-Express (1x) graphics output card. It can be used as a basis for creation of on-air graphic design systems (CG-systems) and broadcasting video servers.

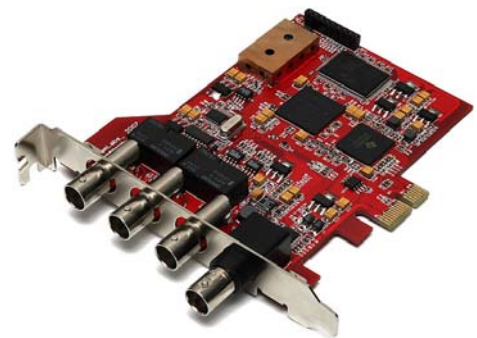

Stream WIND SDI II is designed to work with 8 and 10-bit serial component SDI signals, in accordance with CCIR656 and SMPTE259m standards. SDI embedded audio is supported. Automatic activation of video signal relay bypass mode upon computer power loss.

Synchronization from input SDI signal or analog Black burst (Composite) signal. When external synchronization is absent, internal sync generator is used.

Digital key signal (alpha-channel) output is provided for use with external mixer that has a DSK (Down Stream Key) input. Key signal delay relative to output graphics has a software controlled wide adjustment range.

8-channels (4 stereo pairs) SDI Embedded audio input/output.

When SDI signal passes through the card all the embedded information is kept unchanged, audio can be either kept or changed depending on the situation.

Error control in incoming SDI signals with check total count according to EDH method. EDH packets on the output are formed anew in accordance with SMPTE165 standard.

Specifications:

Size	131x95 mm
Bus	PCI-Express 1x
Inputs	SD SDI (SMPTE 259M and ITU-R BT.601) with embedded audio PAL/NTSC; Analog external synchronization input (genlock) Blackburst (BNC)
Outputs	Composite: PAL/SECAM/NTSC; SD SDI (SMPTE 259M and ITU-R BT.601) with embedded audio PAL/NTSC; Digital linear key DSK signal alpha-channel output (BNC)
Relay Bypass in case of power failure	SD SDI with embedded audio
Alpha channel	256 degrees of transparency
Alpha channel delay adjustment	From -127 to +127 1 pixel each
Adjustment of graphics position relative to sync signal	Within the limits of entire active line with an accuracy to one pixel

WatchDog USB timer

To increase the system operation reliability, it is recommended to use our **WatchDog USB timer device** in the computers operating in automatic round-the-clock mode without constant operator supervision.

This device is designed for continuous control of system condition and inspection of its operability. Its work principle is simple; the system is periodically required to respond to sent enquiries confirming its operability. If the system ceases to respond, it is forced to reload.

Automatic restart is performed by generating a Reset pulse signal, which is similar to the button on the case of a computer.

The device can be applied in any PC that demands increased fault tolerance and automatic operability restoration after software and hardware failures.



Features:

- Is installed in internal 9-pin USB controller connector on the motherboard;
- Has its own USB-connector and allows to install the application security dongle inside the computer system unit;
- High reliability;
- Simple hookup;

- API for software control;
- Programmable USB controller is used;
- Low energy consumption;
- Does not require a separate power supply;
- Small size.

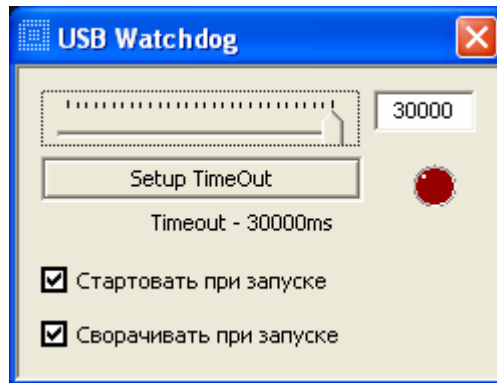
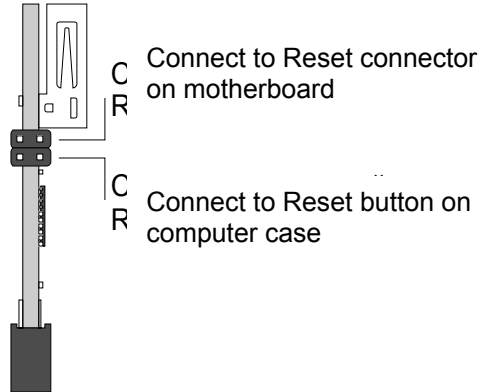

The standard software settings are extremely simple.

It comes bundled with API for software control, which allows a deeper integration of the device into your system, if necessary.

System components – Software

Alpha Pro character generation software

Alpha character generation software working together with Stream ALPHA и WIND SDI titling and graphics overlay devices can perform a wide range of tasks as a part of editing or live TV systems.

The program allows to:

- Perform titling for TV programs during editing or on the air;
- Display text or graphics as a crawl or roll;
- Smoothly execute over 300 special effects (Cut, Wipe, Fade In/Out, Roll, Crawl etc.);
- Create a static or dynamic logo as a symbol for TV channel / program;
- Create information and graphic design for interactive talk shows, news bulletins and sports program;
- Display animated and static logos;
- Play scripts in a loop.

Alpha character generation software, which runs on Windows XP/7, allows you to create scripts and display them with different effects by using Stream ALPHA и WIND SDI graphics overlay cards. The system operates in real time and is designed for titling, commercial block output, and design of live television programs, such as: news, weather forecasts, sports reports, talk shows, etc. This software accumulates years of operational experience (Official program registration certificate dated from 26.08.1997) and the contemporary requirements of professional video production, allowing you to solve the majority of the traditional broadcast design tasks. The software has inherent growth potential and extended functionality through software updates and computer upgrades.

In regards to the design possibilities, the only limit is the artist's imagination. Various fonts, three-dimensional shadows, semi-transparent masks, textures, complex multi-layered compositions, animations and much more is at your disposal.

High quality and simplicity of character generation.

- Using all available Windows TrueType fonts. Supports characters of any language (Unicode);
- Characters and tickers with complex 3D-shadows, borders, contours and outlines;
- Fonts with random direction gradients, textures including images in JPEG, BMP and TGA 32-bit formats;
- Broadcast quality rasterization provided by anti-aliasing;

- Elimination of interlace flicker by flicker filter;
- Inserting images and logos as symbols into crawl text;
- Using 16.7 million colors and 256 transparency levels to color any element on the page.

The principles of text and graphic editors are used to format a frame. You choose a piece of text, up to the individual character, and you can change all of its attributes: font, size, color, transparency, etc. A set of attributes can be saved as a style. When you compose a frame, you are not limited to the number of layers with text and graphics.

Usability and efficiency. From a user perspective, the program looks like a multi-window text editor, which allows you to edit several scripts simultaneously and hold them ready for output. Alpha classic Windows program interface (shortcuts, hotkeys, etc.) and “What You See Is What You Get” (WYSIWYG) mode provide quick and easy mastering of its possibilities by the user.

- Immediate output of titles by using prepared scripts (templates) containing a graphic representation of the page where only a few fields have to be filled;
- Keeping ready several scripts at once, quickly edit and air them;
- Editing certain scripts while the other scripts are being aired.

Wide range of linear effects. The script is divided into pages, the number of which is unlimited. Each page has a visual effect assigned to it, which determines its appearance, movement and disappearance from the video screen.

Alpha Pro application supports and displays over 300 2-D effects smoothly and in sync with pass-through signal fields:

- Vertical Roll – text that runs vertically from bottom to top;
- Horizontal Crawl – "infinite" page of arbitrary height and length, moving horizontally from right to left;
- Reveal / Reveal – horizontal and vertical slide-ins;
- Displaying animated and static logos;
- Fade In / Fade Out / Cross Fade – smooth transition effects;
- Zoom – scaling effect;
- About 300 types of Wipes with "transition softness" setting.

All effects can be displayed on full screen or within a specified rectangular area. This allows you to limit the output of the titles, for example, to the bottom part of the screen, and to keep the static logo at the top, etc. The effects have settings for speed, duration and the value of the subsequent pause.

Alpha Pro Extended version (currently part of default installation)

supports objects control from external applications, including programs developed by the user. These programs can use VBA scripts from Microsoft Office suite, including Word, Excel and Access scripts, Visual Basic based programs, a Web-page, which contain VBScript, and also Delphi and Visual C++ based programs. This makes it possible to display titles on the screen at a set time and modify them in the software immediately before the output.

The program design is set in the form of templates prepared in advance or edited during the broadcast. Operational data is added to the template directly at the time of output. It is possible to automatically update the image on the screen synchronously with the updating of input data.

Using the built-in Internet Explorer language VBScript, you can reduce all program management to one or several HTML-pages that contain edit fields and buttons for the performance of the required actions. By creating an Alpha Pro script with the corresponding templates, you can immediately set the visual style - background, font and effects that will be used to display and clear the screen. This way you get a custom "control panel" without irrelevant and distracting control elements.

A detailed description of Alpha Pro is available on the CD-ROM supplied with the program. It can also be downloaded from our web site www.stream-labs.com.

TELE on-air automation and information / graphic broadcast design software

TELE system is an extension of **Alpha Pro** program, which incorporates all its features. The system provides broadcast automation by scheduling the program output, inserting regional advertising into central channel broadcast, retransmitting other channels, adding titles, bumpers and banners, displaying clocks, logos and much more.

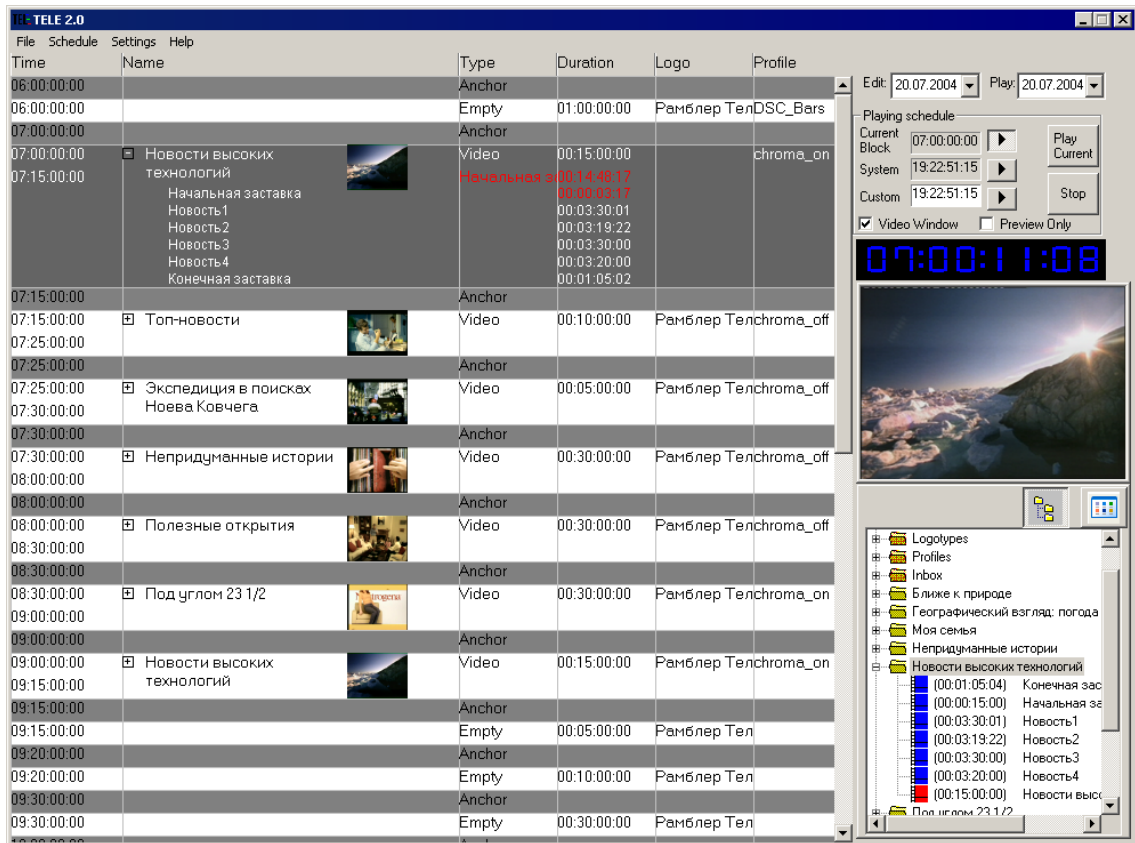

TELE system allows to:

- Display titles for TV programs during editing or on the air by applying effects, crawls and rolls, as it is done in Alpha Pro application;
- Output crawls, banners, commercial blocks and full screen video according to the schedule and in sync with the sound. Provide professional quality video file output in formats generated by various hardware and software companies such as Avid, Pinnacle, Matrox, Canopus and others in real time without preliminary rendering. MPEG-2 in particular, both I-frame and IBP. The system also provides real-time output of video compressed into a variety of formats, such as: MPEG-1/4, QuickTime, Windows Media, Indeo and Cinepak codecs, etc. Moreover, the frequency does not necessarily have to be 25 frames per second and frame resolution in pixels does not have to match the size of the video card buffer – up to full HD. The system allows you to play DVD VOB-files and transport streams. You can play whole video files or parts of them.
- Combine the original video files of various formats to video blocks using the simplest means of editing (trim, straight splice), as well as adjust some visual parameters of the video (brightness, contrast, saturation, etc.).
- Create schedules in user-friendly interface editor and overlay the foreground over clips or pass-through video signal. The foreground is a composition of an unlimited number of logo layers (static or dynamic), crawls, analog and digital clocks, temperature sensor, etc. All this can be

scaled in real time with the picture-in-picture effect, which allows you to organize a Bloomberg style information channel by using the **TELE Info/TELE IP** module (see below).

- Support characters of any language (Unicode).
- During system installation, the menu and program dialogs language selection (Russian or English) is performed automatically, it can be changed later.

TELE package can be supplemented with modules that provide additional functions.

DvDelay software module

The program (which is part of default installation of **TELE/TELE Info/TELE IP**) features reception of digital stream from capture devices installed or connected to PC, delay of the stream for designated period of time and then outputting it into **TELE, TELE Info /TELE IP** replacing the incoming stream. In addition, delayed stream can be used as an entry in a scheduler or as a source for foreground compositions in Overlay windows (see below).

Constant delay of video and audio streams could be set; and also RAID array can be used for recording in order to avoid premature wear of hard drives

Detect software module

The program (which is part of default installation of **TELE/TELE Info/TELE IP**) automatically detects the beginning and the end of the regional advertising window by a musical signature transmitted in the audio channel of the central television channel.

The program works together with the schedule, forcing **TELE/TELE Info** to start the output of selected video blocks depending on current system time, or to stop the output. In addition, the program can perform similar actions by accepting GPI-signals through the computer game port.

Thermo software module

Program stands for transfer data with values of temperature from meteorological sensor "TUNDRA"; or data with values of temperature, pressure and humidity from meteorological station manufactured by us.

TELE Info software module

Many TV-channels, like CNN, Bloomberg, RAI-24 have highly intensive graphic design, which is distinguished by simultaneous output of several crawls, animated logos, and information fields with constant content update. These channels usually have video feed scaled into a window, while the remaining space is occupied by graphic elements.

ТЕЛЕ СПОРТ
22 июня 2004г

Euro2004
PORTUGAL

Группа А

	И	В	Н	П	ЗГ	ПГ	О
Португалия	3	2	0	1	4	2	6
Греция	3	1	1	1	4	4	4
Испания	3	1	1	1	2	2	4
Россия	3	1	0	2	2	4	3

Группа В

	И	В	Н	П	ЗГ	ПГ	О
Франция	3	2	1	0	7	4	7
Англия	3	2	0	1	8	4	6
Хорватия	3	0	2	1	4	6	2
Швейцария	3	0	1	2	1	6	1

Россия 2-1 Греция (2'- Кириченко, 17'- Булыкин; 43'- Вризас)

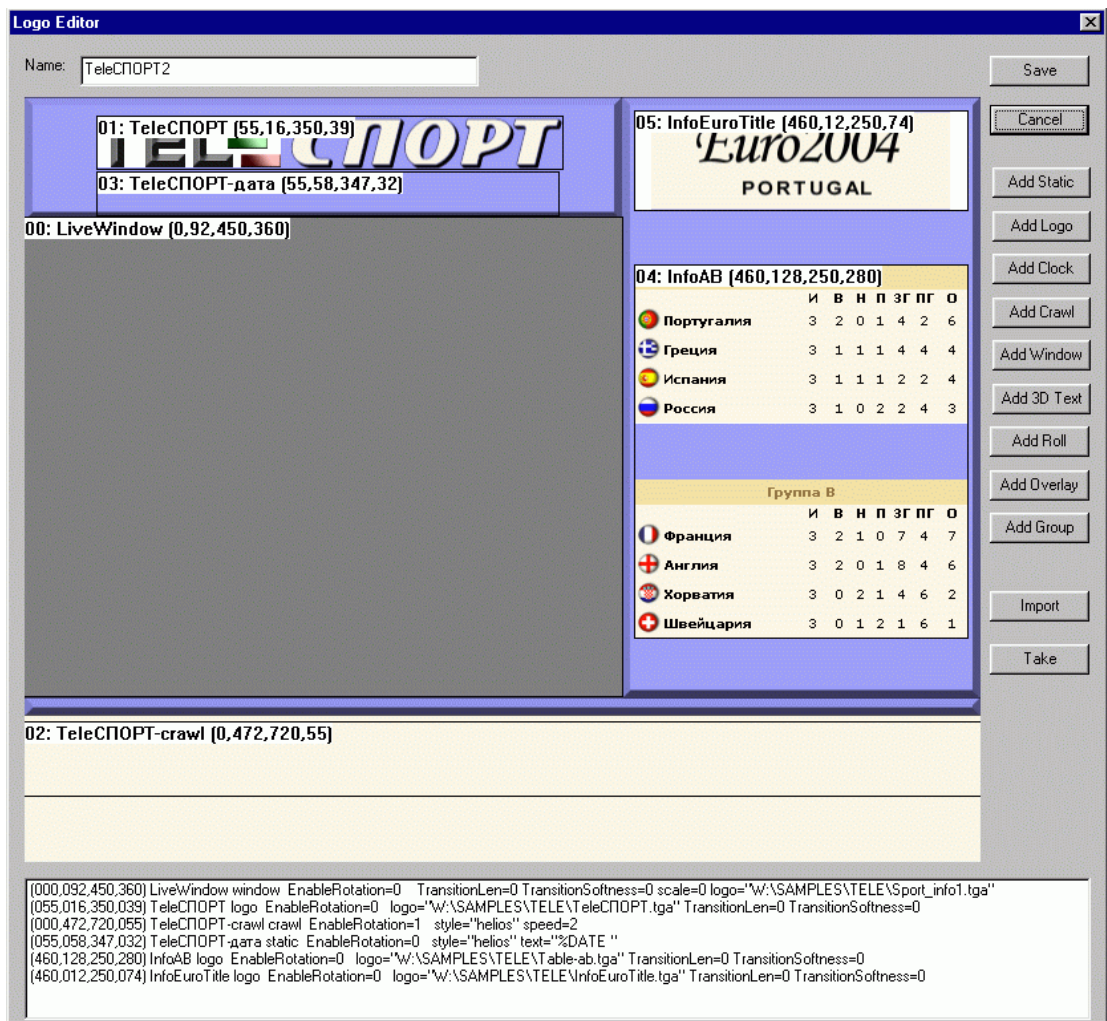

TELE Info module allows to:

- Design the programs in this style, filling round-the-clock broadcast with advertising and informational messages, the rotation mechanism will simplify the playlist compilation by rotating the data displayed in the design elements. For example, you can organize a personal music channel as a fully automated clip rotation with titles (song name, artist, etc.);
- Scale video clips showing them in one or two "windows", surrounded by a variety of graphic elements - logos, crawls, temperature, pressure, humidity sensor readings, currency rates, etc. The information in the crawls is displayed on the fly, which allows visualizing real-time data or, for example, setting up an SMS-chat support. The crawl can run directly over the video played by the system;
- Run a DV recorder and get video signal through FireWire interface or another digital source. Embed this signal on the fly without using a mixer or preliminary recording in the computer;
- Display a rectangular area of Windows Desktop on the TV screen in real-time, while performing scaling, color correction and smoothing fine horizontal lines (Anti-Flicker);
- In addition, an open API **SDK** (available separately) can help in the

development of custom applications for specific programs and system integration into existing studio complexes. The system has a built-in module for programming (editing) and writing personal programs in Visual Basic. This makes it possible to adapt the system for the transmission of programs in mixed mode (live and the output of prepared beforehand material sequence).

- The package includes **SMS Terminal** application.

TELE IP

Program **TELE IP** is matching to **TELE Info** with its features. The difference is that **TELE IP** does not use incoming video signal from video card and forms output stream for broadcast into local network or for broadcast into Internet through Media Server. During installation you can choose either MPEG2 or H.264 format for transport stream for local network; or default parameters (which could be changed later on) for Adobe, WOWZA, Windows Media Servers. There is a choice for broadcast to additional screen using ATI VGA adapter with its HDMI out for LCD panel.

Resolution may vary up to Full HD (1920x1080; however, the latter requires corresponding power of CPU. Quality (amount of pixels) of digital output can be also adjusted.

TELE Info IP

Program **TELE Info IP** combines features of **TELE Info** which uses incoming video signals generated by Streamlabs' video cards and concurrent broadcast fo output signal either into local network or through Media Server.

Output video signal from Streamlabs' video card is being digitalized by Aver Tuner HD or Decklink cards and resulting stream is being coded for further broadcast according to settings of **TELE IP**

SMS Terminal software module

SMS Terminal program module designed for broadcast automation is equipped with most popular services, which can be used together and in various combinations:

- Broadcasting text and multimedia (graphic) messages, organizing the moderation of incoming messages;
- Voting by using set templates with alternating number of answer choices. You can display the number of votes, their percentage and the

results in the form of a scale. You can also receive calls and voting results from other programs;

- Automatic rotation of clips based on votes. The number of votes determines the playback of a clip;
- Automatic output of news blocks from RSS feeds;
- Titling “on the fly” during news blocks production and live broadcasts from the studio;
- Displaying announcements and news tickers.

The program can work together with the clip output from the schedule process in **TELE**, or independently.

SMS Terminal comes with additional utilities for calls and SMS messages reception, i.e. via the either Internet or GSM modem.

More information on **TELE / TELE Info** software and latest news can be found on the developers’ website – www.alpha-pro.ru

Package contents

- ✓ Video card (except **TELE IP** package).
- ✓ This hardware installation and operation guide in printed form.
- ✓ Software on CD-ROM with demonstration examples.
- ✓ USB electronic security key.
Attention! In case of USB key loss or physical damage, the client will be required to purchase a new key for the full price in order to continue operating the system.
- ✓ Software User Manual supplied in hardcopy or on CD-ROM in PDF format.

Depending on the specific video card model the package may include:

- **Stream Alpha Plus PCI-E (optional)**: 15 pin adapter – 4xBNC for connection to an external mixer through DSK input - YUV + Alpha Key, or RGB + Alpha Key.
- **Stream Alpha Plus PCI-E (optional)**: Audio BYPASS card, which enables / disables bypass of audio channels simultaneously with a similar mode for pass-through video signal.
- **Stream Alpha Plus PCI-E (optional)**: Stream Audio extension card with analog and digital mixing functions for the pass-through and played back audio channels, and audio bypass mode upon computer power cutoff.

- **Stream Alpha SDI (optional):** 15 pin adapter – 7xBNC for connecting YUV-ins/outs and KEY signal (alpha channel).

Assignment of card connectors

Before installing and connecting Stream Alpha overlay cards, please familiarize yourself with the location and assignment of the card connectors.

Stream ALPHA Plus PCI-E

- **S-Video Output:** miniDIN-4 connector, S-Video (Y/C) output.
- **Composite Output:** BNC connector, Composite PAL, SECAM, NTSC output.
- **S-Video Input:** miniDIN-4 connector, S-Video (Y/C) input.
- **Composite Input:** BNC connector, Composite PAL, SECAM, NTSC input.
- **YUV+Key/RGB+Key Output:** 15 pin D-SUB connector, for connection of a VGA cable with BNC outputs: Y/G, Cr/R, Cb/B (green, red and blue, respectively) and Key - yellow.

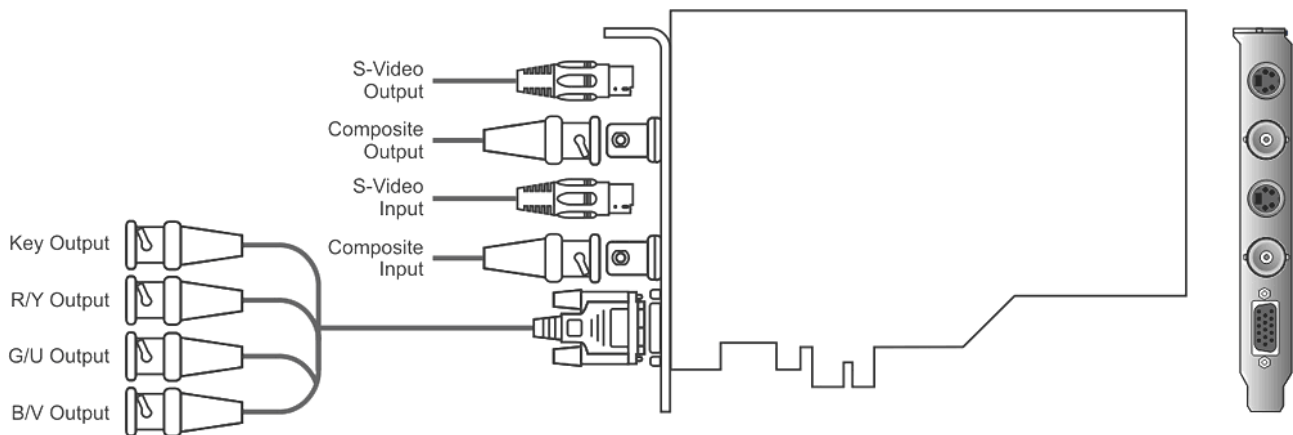

Cable with additional connectors is not included in the standard package and is available separately.

15 pin connector pinout

1	2	3	4	5
R/Cr	G/Y	B/Cb	-	-
6	7	8	9	10
Ground	Ground	Ground	-	Ground
11	12	13	14	15
-	-	Key	-	Relay

Analog and digital mixing modes

When digital decoding mode is activated, you can use any combination of connections. This allows you to choose the video card output standard different from the input standard.

When the card is connected according to PAL Composite - PAL Composite or PAL S-Video - PAL S-Video scheme without digital

decoding (and subsequent coding), the input signal passes through the video card without any changes.

Analog mixing *

INPUT	OUTPUT
PAL Composite	PAL Composite RGB Fill + Key 50Hz YUV Fill + Key 50Hz
PAL S-Video	PAL S-Video RGB Fill + Key 50Hz YUV Fill + Key 50Hz
NTSC Composite	NTSC Composite RGB Fill + Key 60Hz YUV Fill + Key 60Hz
NTSC S-Video	NTSC S-Video RGB Fill + Key 60Hz YUV Fill + Key 60Hz

Digital mixing **

INPUT	OUTPUT
PAL/SECAM Composite or S-Video	PAL/SECAM Composite or PAL/SECAM S-Video RGB 50Hz YUV 50Hz RGB Fill + Key 50Hz YUV Fill + Key 50Hz
NTSC Composite or S-Video	NTSC Composite or NTSC S-Video RGB 60Hz YUV 60Hz RGB Fill + Key 60Hz YUV Fill + Key 60Hz

* In analog mixing mode, only the graphics in component format are outputted from the 15 pin connector.

** In digital decoding/coding mode, the same data as on the main output is outputted from the 15 pin connector in component format.

Audio BYPASS expansion module for Stream ALPHA Plus PCI-E card

- **Audio Input:** RCA connector – Audio Line-in (stereo).
- **Audio Output:** RCA connector – Audio Line-out (stereo).
- **Sound Card In:** Phonejack Stereo connected to the computer sound card Line-in.
- **Sound Card Out:** Phonejack Stereo connected to the computer sound card Line-out.
- **Connector 2x8 pin**, which is connected by cable to a similar connector on video card Stream Alpha Plus PCI-E.

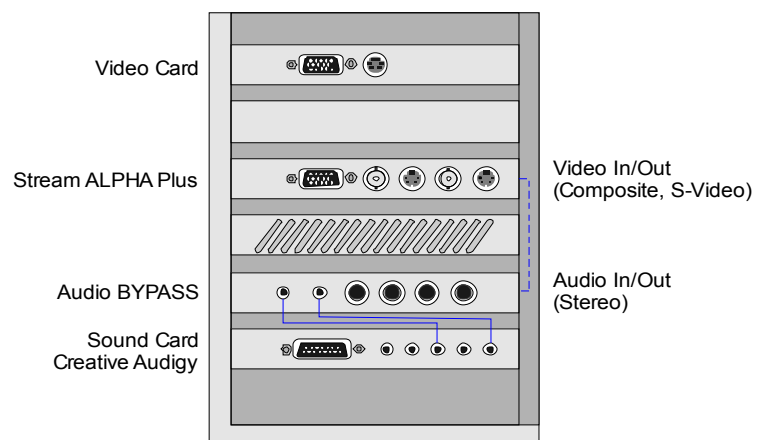
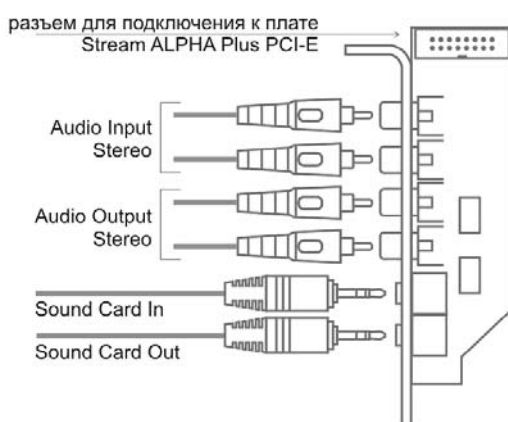

Stream Audio extension sound card

- **Audio output (balanced analog):** TRS 1/4' balanced stereo out.
- **Audio input (balanced analog):** TRS 1/4' balanced stereo in.
- **Line In (Stereo):** Phonejack Stereo Line-in.
- **Line Out (Stereo):** Phonejack Stereo Line-out.
- **Connector 2x8 pin**, which is connected by cable to a similar connector on video card Stream Alpha Plus PCI-E.
- **Power connector (Molex 4 pin)**, which is connected by cable to corresponding connector of PC's power supply.
- **Sensitivity (jumpers Jp1, Jp2):** middle & left – 200mB; middle & right – 0.775B
- **Input impedance of balanced input (jumpers Jp3, Jp4):** middle & left – 18 kOm, middle and right – 600 Om.
- **Sensitivity on asymmetric output 3.5 mm (jumpers Jp5, Jp6):** middle & left – 200mB, middle & right - 0.775 B.

NOTE! Hook up head phones only when jumpers Jp5 and Jp6 are in **middle & left**

position.

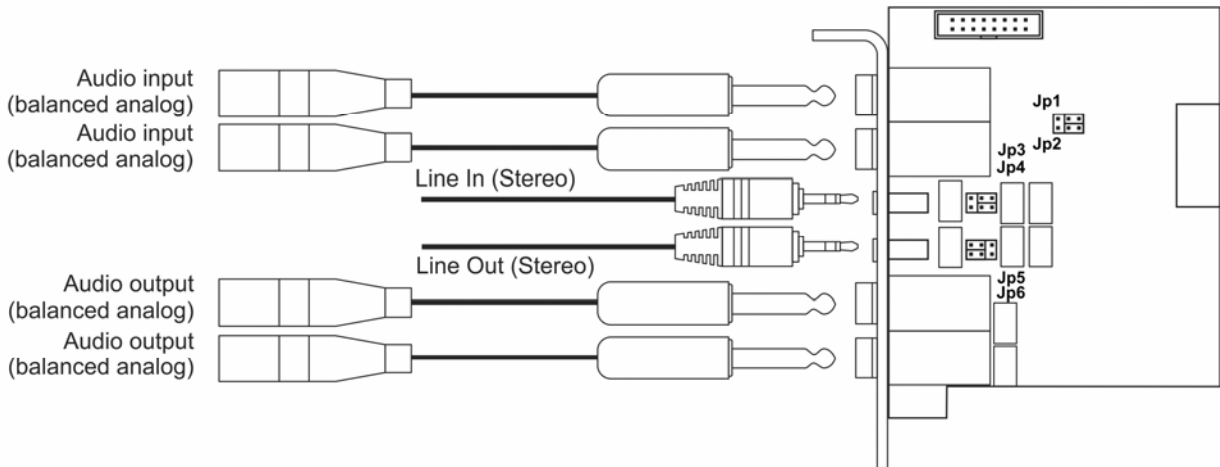

Stream ALPHA SDI

The card has three BNC connectors, one RCA connector and one D-SUB 15 pin connector, which can be connected to a special adapter cable that has two sets of BNC connectors. The first set – analog inputs Y, Cr, Cb (green, red and blue, respectively). The second set – analog key signal output (white) and 3 outputs – Y / Composite, Cr, Cb (green, red and blue, respectively).

- **Composite Input:** RCA connector – Composite video or sync signal input.
- **SD SDI Input:** BNC connector – SD SDI signal input.
- **SDI Key Output:** BNC connector – SD SDI Key signal output.
- **SD SDI Output:** BNC connector – SD SDI Fill signal output (SMPTE 259M).

Attention! The video card will not work without **input video signal or sync signal** connected.

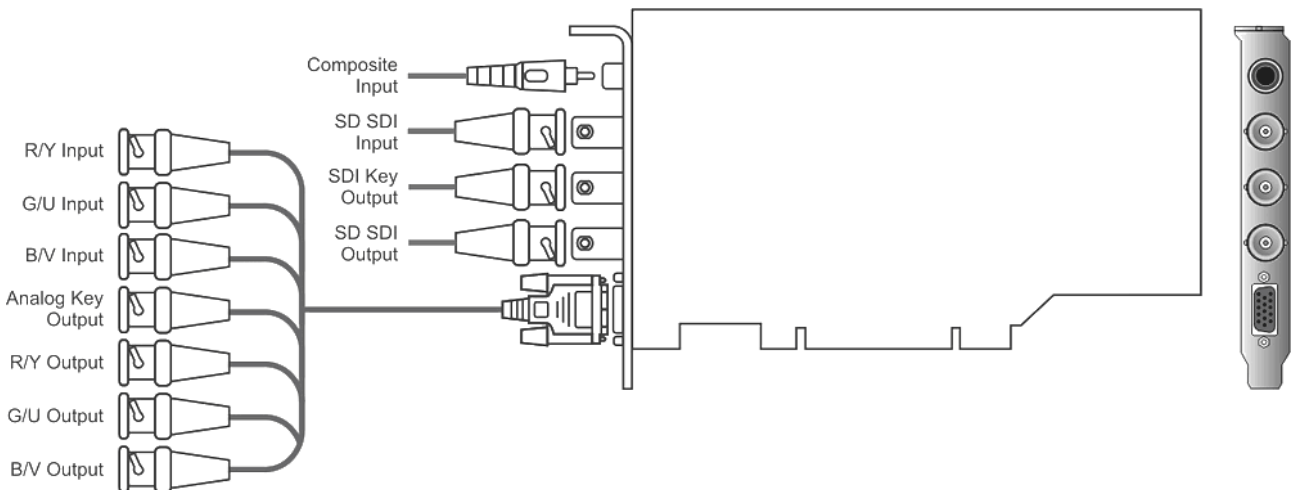

15 pin connector pinout

1	2	3	4	5
Cr Out	Y/Comp Out	Cb Out	-	-
6	7	8	9	10
Ground	Ground	Ground	-	Ground
11	12	13	14	15
Analog Key	Y In	Cb In	Cr In	-

Stream ALPHA WIND SDI

- **Reference Input:** BNC connector – analog sync input.
- **SD SDI Fill Output:** BNC connector – SD SDI Fill signal output (SMPTE 259M).
- **SD SDI Key Output:** BNC connector – SD SDI Key signal output.
- **Composite Preview Output:** BNC connector – Preview signal output.

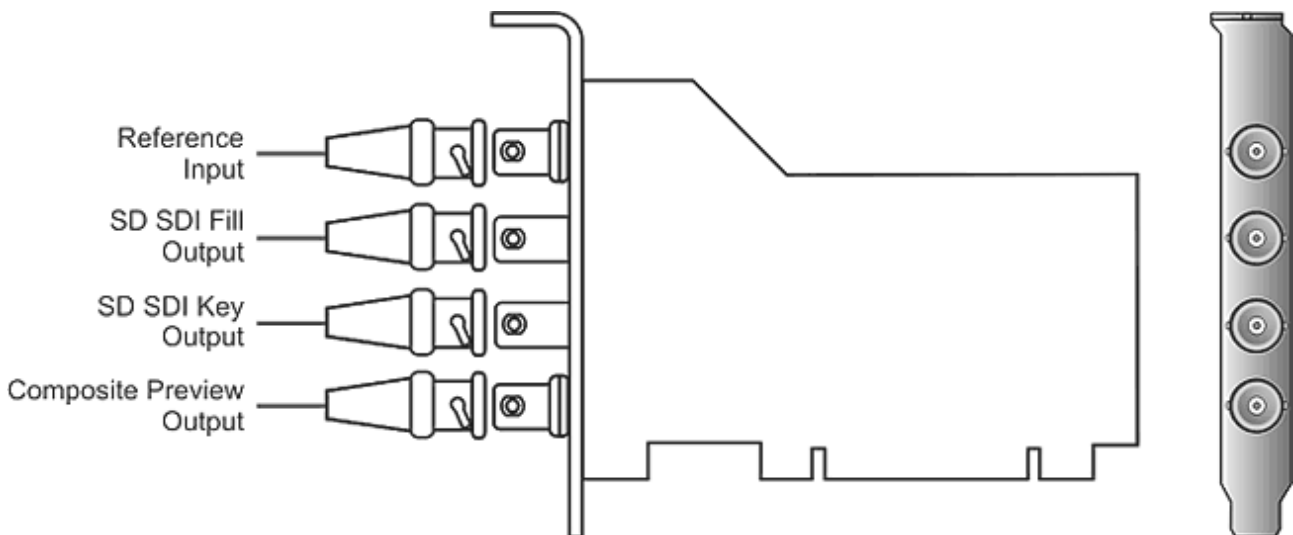

Stream ALPHA WIND SDI II

- **CVBS Reference / SD SDI Input:** BNC connector – analog sync or SD SDI signal input.
- **SD SDI Output:** BNC connector – SD SDI signal output (SMPTE 259M).
- **SD SDI Key Output:** BNC connector – SD SDI Key signal output.
- **CVBS Reference / CVBS Preview Output:** BNC connector – analog sync input, or Preview signal output.
- **J8 - CVBS Reference:** 2 pin connector for an alternative analog sync input.

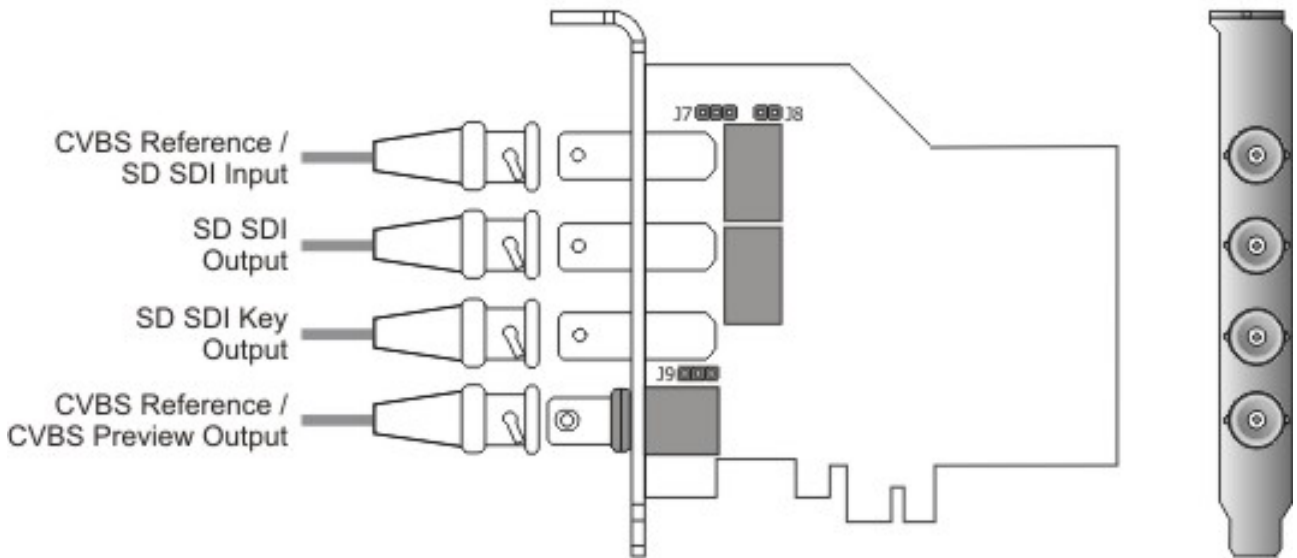

Input/output operating modes

- The **CVBS Reference / SD SDI Input** receives an SDI signal (it is also the sync signal), the remaining connectors are the corresponding outputs - the **middle** and the **right** contacts are closed on **J7** and **J9**. In this mode, the card provides video relay bypass between SDI input and SDI Fill output.
- The **CVBS Reference / SD SDI Input** receives analog sync, the other connectors are the corresponding outputs - the **middle** and **left** contacts are closed on **J7**, **middle** and **right** contacts are closed on **J9**. In this mode, the video card works similarly to Stream WIND SDI.
- The **CVBS Reference / CVBS Preview Output** receives analog sync, the other connectors are the corresponding inputs/outputs - the **middle** and the **right** contacts are closed on **J7**, **middle** and **left** contacts are closed on **J9**. In this mode, the video card can capture SDI signal from the SDI input.

Connection diagrams

Pass-through connection

When it is not possible to connect the system to work “through a mixer”, it can be connected “pass-through”, i.e. the signal, to which the titles and the graphics get mixed, is sent to the Stream ALPHA card input, and the resulting signal is taken from the output and broadcasted.

The system operating in this mode should comply with certain requirements. Primarily, it concerns the stability and reliability of the system. The reliability of a personal computer based system can be determined not only by the quality of the overlay card and associated software, but by the other components as well. Therefore, to avoid possible trouble on the air, upon power off or BYPASS mode activation, the input and output close on each other through the relay and the pass-through video signal passes through the system without any changes on all Stream ALPHA cards. Stream ALPHA cards also have a Preview output, which lets you preview the information before you air it.

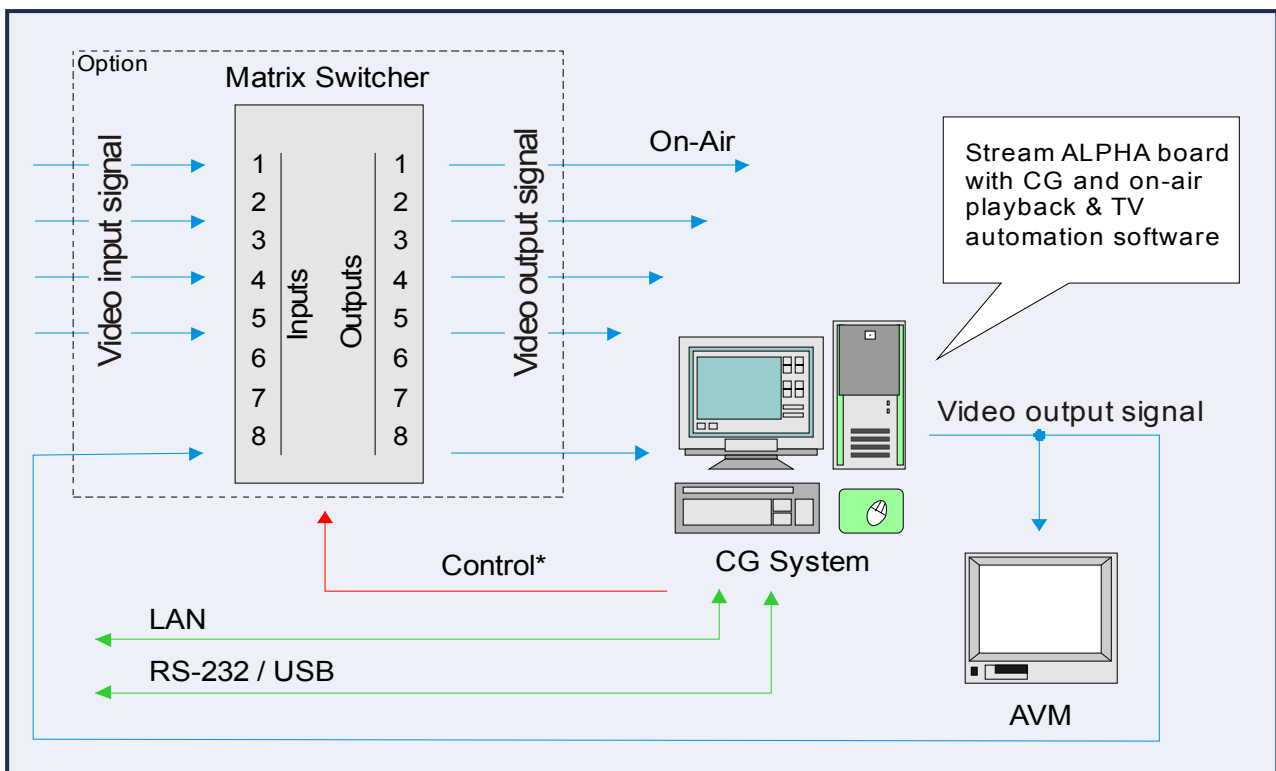

* It is possible to control external devices such as transcoders, mixers and switches (ITM, TELEVIEW, KRAMER) through TELE / TELE Info /TELE IP software.

Through the mixer connection

For use with an external mixer with DSK (Down Stream Key) input, all Stream ALPHA cards feature an output for the key signal generated by the card and an option to deactivate the mixing of graphics with the pass-through video signal inside the card via alpha channel. The card

configuration program allows to specify both positive and negative delay for the displayed graphics and key signal in relation to the input synchronization. This feature allows you to use your video card in this mode to work with mixers that do not have their own delay line on DSK input.

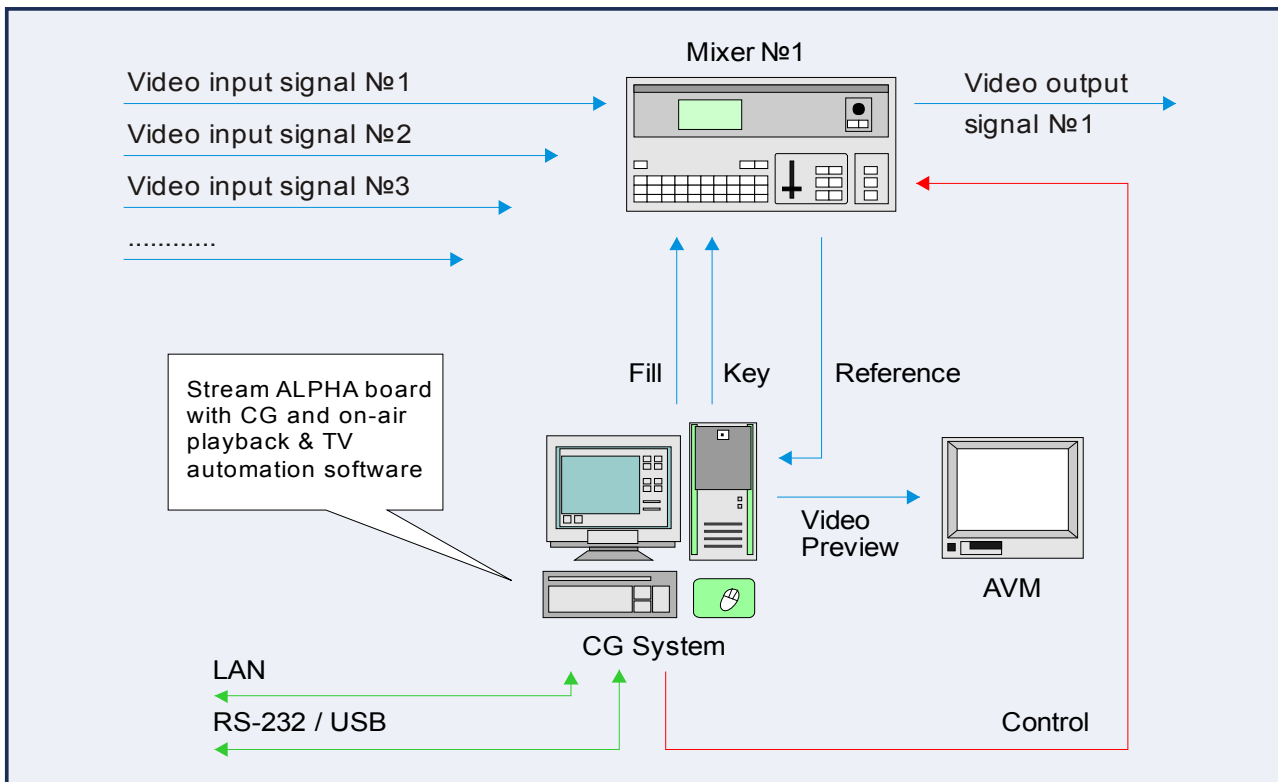

Connecting the system through the mixer to multiple channels

In this mode, one system in a regional station services several channels retransmitted according to the schedule. Practically always, the retransmitted channels are not synchronized with each other, so it is necessary to use a synchronizing mixer or a switchboard. The sync signal is constantly fed to the system input, and the output Fill and Key signals are sent to the DSK mixer input. This control line from the system to the mixer allows you to output the graphics at the right time in accordance with the schedule.

Connecting the systems into a network allows you to organize a remote operator interaction with them, to display all incoming information on-the-fly, and to manage centralized information output from several systems by using an integrated program. Additional devices can be connected to the systems through COM and USB ports.

Installation and connection

- A. Open the computer and install the video card into any available slot. Be careful when inserting the card. Keep your fingers around the perimeter of the card, avoid touching the voltage regulators and other elements installed on the card so as not to damage them.
- We do not recommend installing the video card into a slot next to the video adapter, which usually gets very hot. The overheating of Stream ALPHA card may lead to the deviation of some of the card's parameters from the values specified by the manufacturer.
 - If you're installing the Stream ALPHA card into a case which is not provided with additional cooling, we recommend using the System Cooler for PC device and installing it close to the video card chips.

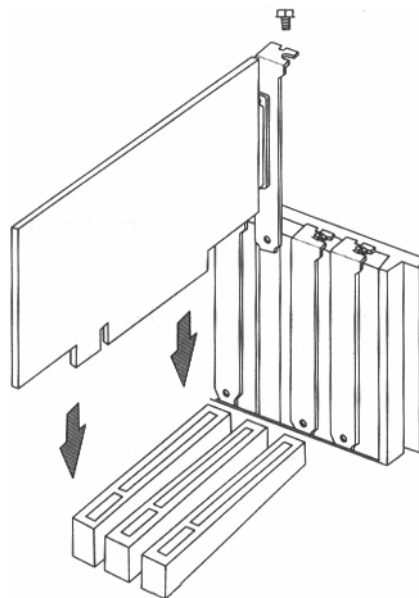

- B. Close the computer (USB electronic security key should be inserted in the computer only after its drivers are installed).
- C. Connect the input and output on the card to the corresponding video equipment outputs and inputs in the studio. Additional comments:
- **Stream Alpha Plus PCI-E.** When using a VCR as a video source, use a VCR with Time Base Corrector. When using a household VCR, the quality of the output signal cannot be guaranteed. If you use both S-Video and Composite signals, we recommend using S-Video signal, as it provides significantly better image quality.
 - **Stream Alpha SDI.** When working with this card, it is **mandatory** to provide a video signal on one of the inputs (SDI, YUV, Composite), or a sync signal.

When you use this card in the overlay over the pass-through signal mode, the same mixing result will be displayed on **all** video outputs (SDI, YUV and Composite).

When working with an external mixer, it is still necessary to connect the sync signal to one of the video card inputs.

- **Stream WIND SDI** can operate with or without external synchronization input signal. To ensure the Genlock mode, provide an analog synchronization signal to the video card **Reference** input.
- **Stream WIND SDI II** can operate with or without external synchronization input signal. To ensure the Genlock mode, provide an analog synchronization signal to the video card **CVBS Reference** input. You can use synchronization from **SD SDI Input**.

In addition, the card has a pass-through mode with SDI signal and an analog Preview signal on the SDI output. Selecting the necessary option is performed by switching the jumpers.

The card can work with audio embedded in the input SDI signal, and form it on SDI output.

- D. Connect the source and the audio signal receiver (for work with TELE). Regular computer sound cards do not provide a pass through channel mode when the computer power is turned off without loading the appropriate drivers in the operating system. If necessary, you can use an external audio bypass block, or a special Stream Audio card for Stream Alpha Plus PCI-E video card (see above).

In the course of its operation, TELE can automatically send the input channel on the output, or turn on the audio output from your computer. After exiting the system, the sound from the computer is turned off (the pass through channel is left).



ATTENTION! The computer and video equipment should be powered from a single power source. The computer must be grounded. If a spare ground cable is available in your power mains, you should use it; otherwise the grounding cable can be laid out from the power distribution board (use qualified personnel services to do this). The quality of the grounding will determine the safety of your equipment and image quality. To minimize the interference, it is recommended to connect the cases of the computer and the video equipment with one wire.



ATTENTION! Do not switch the connection cables while the computer or video equipment is operating. This will damage the video system, computer and video equipment. Prior to any switching operation, all equipment must be de-energized by disconnecting the power cables (the connection of cases of the devices to earth and to each other should be left intact)!

- E. Turn on the computer and follow the manual located on the CD-ROM to install the electronic protection key drivers, and then the software itself. The same manual describes the settings for your video card.

Adjusting the settings for Stream Alpha series video cards in Alpha Pro / TELE applications

This section describes the parameters and configuration options for the Stream Alpha series cards (hereinafter – “card”). The configuration is performed in the Alpha Pro dialog window which is called by pressing the Video => Hardware Options menu. After the parameter name, its default value upon the program installation is specified in square brackets, for example - [0], [PAL] etc. [] means that the corresponding box is not checked.

Stream Alpha Plus PCI-E

Digital conversion [].

A checked box signifies that the input video signal decoding, **digital** mixing with the image stored in the card buffer and subsequent coding on the output mode is enabled. Only in this mode, you can change the output format and standard of input video signal, and implement a mix of SECAM input video signal with the image stored in the card buffer. However, in this mode, there is a delay in signal when it passes through the card (not more than 25 microseconds), besides, all the additional service information from the vertical drive pulse (teletext, time code, etc.) is not transferred to the output.

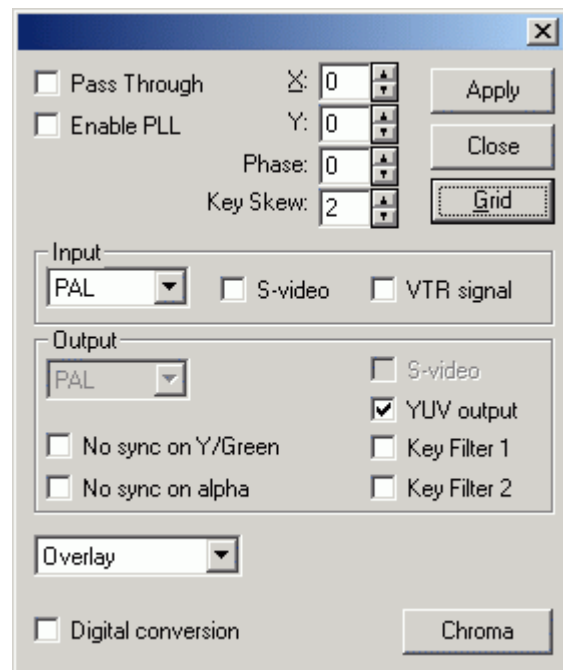

If the box is not checked, **analog** mixing of the incoming video signal with the image recorded in the card buffer is performed. In this mode, the standard, format and quality of input video signal does not change at the output, additional service information in the vertical drive pulse remains.

Pass Through [].

A checked box means that the pass through video signal mode is enabled. Composite and S-Video inputs are connected directly to the corresponding outputs. The card stays in this mode before the Alpha Pro program loads.

Enable PLL [].

A checked box means that the phase locked loop is enabled on the video decoder.

- If there is no input video signal on the card, the box should be checked;
- If input video signal is present, or if there is a short-term loss of the input video signal, it is not necessary to mark the checkbox.

X [0].

In analog mixing mode - a horizontal shift of the image recorded in the card buffer together with the key signal relative to the input signal or sync signal in increments of $\frac{1}{2}$ pixel. The range of allowed values is from “-229” to “+790”. When selecting the parameter value, set it approximately at first, and then, changing by 1, set it precisely. The direction of variation - increase or decrease, may vary and it depends on the particular sync signal. Adjusting this parameter may be required if your mixer does not have a separate sync output signal or delay line on DSK input.

Y [0].

Not used.

Phase [0].

In analog mixing mode - phase shift of color subcarrier frequency in the range from -360 to 360 degrees (the value of “-255” to “+255”, respectively). Adjusting this parameter may be required when using the mixer composite DSK input, if there is distortion or absence of color on the card output. Recommended value for PAL is “0”, for NTSC – “-15”.

Key Skew [0].

Output key signal delay relative to the image signal recorded in the card buffer - from “-72” to “181” in increments of $\frac{1}{2}$ pixel. Adjusting this parameter may be required at internal mixing of the input video signal and image recorded in the card buffer, and when working with an external mixer. Recommended value for analog mixing is “2”, for digital – “6”.

Input – input video signal parameters

[PAL].

Choose the standard of input video signal from the list - PAL, SECAM or NTSC.

S-Video [].

When the checkbox is marked, connect S-Video input signal to the card, when the box is unchecked, connect composite signal.

VTR signal [].

Not used.

Output – output video signal parameters

[PAL].

Select the standard of output video signal from the list - PAL, SECAM or NTSC. In analog mixing mode this parameter can not be changed – the output video signal standard remains the same as the input. In digital mode you can select between PAL and SECAM input signal standards.

S-Video [].

The marked box indicates that S-Video video output format is generated, the unchecked box indicates that Composite video output format is generated. In analog mixing mode this option can not be changed - the output video format

is the same as that of the input. In digital mixing mode the input format can be changed from Composite to S-Video, and vice versa.

YUV Output [v].

The marked box indicates that YUV video signal is present on RGB/YUV+Key output, if the box is not checked, RGB is present on RGB/YUV+Key output.

No sync on Y/Green [].

If the box is not checked, an additional sync signal is embedded in the luminance signal Y (or Green). The marked box indicates that the luminance signal is issued without synchronization signals.

No sync on alpha [].

If the box is not checked, an additional sync signal is embedded in the key signal (alpha). The marked box indicates that the key signal is issued without synchronization signals.

Key Filter 1 [].

Not used.

Key Filter 2 [].

Not used.

Mode of mixing the input video signal with the image recorded in the card buffer

[Overlay].

Select the mode of mixing the input video signal with the image recorded in the card buffer from the list:

- Overlay – input video signal and image recorded the card buffer mix on alpha channel.
- Replace Sync – input video signal and image recorded the card buffer mix on alpha channel, but the sync signals are generated by the card (Genlock mode is preserved).
- Graphics Only – only the image recorded the card buffer is outputted.
- Video Only – only the input video signal, possibly converted to a different standard or format, is outputted.

Chroma.

This button calls the Chroma key configuration window in Alpha Pro application. In this mode, the overlay is performed with decoding the input video signal.

Sound Pro.

Upon loading, the program automatically detects an additional option for working with audio - Sound Pro. In case you still need to use the computer sound card for audio input and output, you should check the box in Alpha Pro \ Video \ Video Playback Options \ Sound \ Disable h/w Audio settings and select the audio device from the Sound Device list. After this, restart your computer.

Stream ALPHA SDI

Input [Composite].

By default, the card is configured for input Composite signal. Therefore, if you apply SDI, S-Video, or YUV signal on the card input, you should select it in the list (**S-Video input is not supported at this time**). Also, analog or SDI input timing reference signal is required.

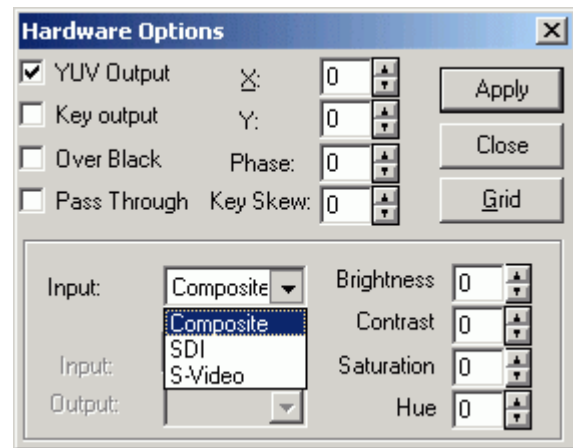

Brightness, Contrast, Saturation or Hue [0].

When using Composite, S-Video or YUV input signal, you can specify its digitization parameters.

YUV Output [v].

This option enables the YUV format output mode on the 15 pin connector. When disabled, Y contact outputs Composite signal.

Key output [].

When connecting Stream Alpha SDI card to a mixer for external mixing, this box must be checked.

Over Black [].

When connecting Stream Alpha SDI card to the mixer (**Key output** box), you can in addition enable the mixing of computer graphics with pass-through black video signal.

Pass Through [].

When this mode is enabled, SDI output (only) is connected to the corresponding input through the relay contacts; the 75 Ohm load on the card is disabled.

X [0].

Horizontal shift up to $\pm 1,727$ points of the output and key signal relative to the reference input signal. It is used only when working with an external mixer.

Y [0].

Not used.

Phase [0].

Not used.

Key Skew [0].

Adjustable key signal delay relative to the output graphics signal – up to ±127 points. Works with internal mixing and with external mixer.

Stream WIND SDI

[PAL].

Select the input and output video standards from the list:

- Reference and Composite Preview - PAL or NTSC,
- SD SDI Fill and SD SDI Key – SDI 625/50 or SDI 525/60, respectively.

[Internal].

Select the card synchronization mode from the list:

- **Internal** - input sync signal is absent or ignored by the card,
- **Analog** - CVBS Reference,
- **SDI** – no (the card cannot use SDI signal for synchronization).

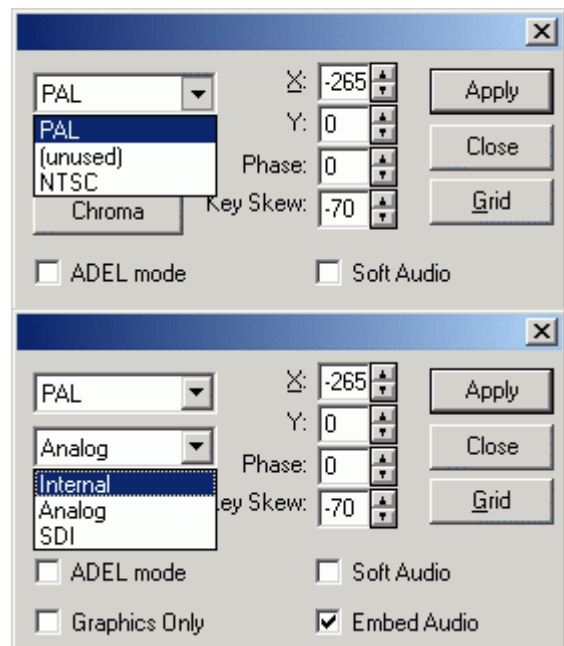

X [0].

Horizontal shift of the image recorded in the card buffer together with the key signal relative to the input sync signal in increments of 1 pixel or 0.037 microseconds. The range of allowed values begins at -265, and at this value it reaches the minimal variance of the synchronization signal and output SDI Fill (approximately 4,333 microseconds). Adjusting this parameter may be required if your mixer does not have a separate sync output signal or delay line on DSK input.

Y [0].

Not used.

Phase [0].

Not used.

Key Skew [0].

SDI Key output signal delay relative to SDI Fill image signal in increments of 1 pixel or 0.037 microseconds. The range of allowed values begins at -70, and at this value the synchronization of the output SDI signals is achieved.

Chroma.
Not used.

ADEL mode [].
Not used.

Graphics Only [].
Not used.

Soft Audio [].
Not used.

Embed Audio [].
The marked box means that the card embeds the audio into SDI Fill output signal. When the box is unchecked, the audio output applications use the computer sound card. In this case, mark an additional checkbox in Alpha Pro \ Video \ Video Playback Options \ Sound \ Disable h/w Audio settings and select the audio device from the Sound Device list. After this, restart your computer.

Stream WIND SDI II

[PAL].
Select the input and output video standards from the list:

- CVBS Reference and CVBS Preview - PAL or NTSC,
- SD SDI Input, SD SDI Output and SD SDI Key – SDI 625/50 or SDI 525/60, respectively.

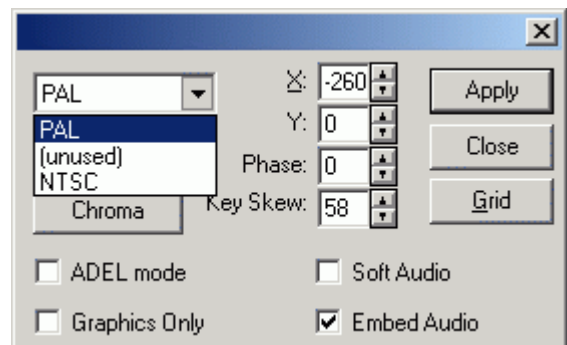

[Internal].
Select the card operation mode from the list (in addition, the jumpers on the card should be properly installed - see above):

- **Internal** - input signal is absent or ignored by the card,
- **Analog** - CVBS Reference,
- **SDI** - SDI Input or SDI Reference.

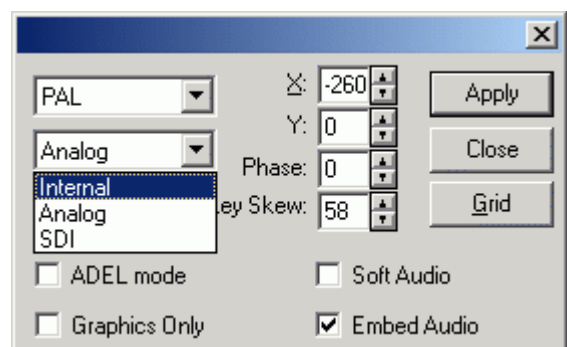

X [0].
Horizontal shift of the image recorded in the card buffer together with the key signal relative to the input sync signal in increments of 1 pixel or 0.037 microseconds. At -260 value, a conformity in input and output SDI Fill synchronization is achieved. Adjusting this parameter may be required if your mixer does not have a separate sync output signal or delay line on DSK input.

Y [0].

Not used.

Phase [0].

Not used.

Key Skew [0].

SDI Key output signal delay relative to SDI Fill image signal in increments of 1 pixel or 0.037 microseconds. At 58 value, a conformity in SDI output signals is achieved. (**ADEL mode** checkbox must be unchecked).

Chroma.

This button calls the Chroma key configuration window in Alpha Pro application. This mode can be used with the SDI input signal.

ADEL mode [].

When you work with modern mixers this option should be unchecked. Previously, it was marked by default, resulting in a shift of SDI Key sync relative to the SDI Fill image signal in 4,852 microseconds. However, it is possible to shift the alpha channel values in SDI Key signal so that they match well with the graphics in the SDI Fill by using **Key Skew**, although the synchronization of these signals is different.

Graphics Only [].

This box is checked to turn off the graphics overlay mode over the SDI input signal (which is used in this case only for the card synchronization). In other card input modes the value of this checkbox is unimportant, since the overlay is not made.

Embed Audio [].

The marked box means that the card processes and generates the audio embedded into SDI signal. When the box is unchecked, the audio input and output applications use the computer sound card. In this case, mark an additional checkbox in Alpha Pro \ Video \ Video Playback Options \ Sound \ Disable h/w Audio settings and select the audio device from the Sound Device list. After this, restart your computer.

Soft Audio [].

This checkbox is used when you select **Embed Audio**, it means that the card while forming an audio stream in the SDI output signal embeds the computer sound into it, and leaves the other input audio streams unchanged. When this box is unchecked, only one audio stream is formed in the SDI output signal.